

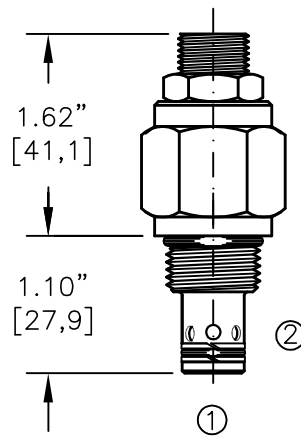

FLOW CONTROL VALVE WITH OR WITHOUT FREE REVERSE FLOW CHECK

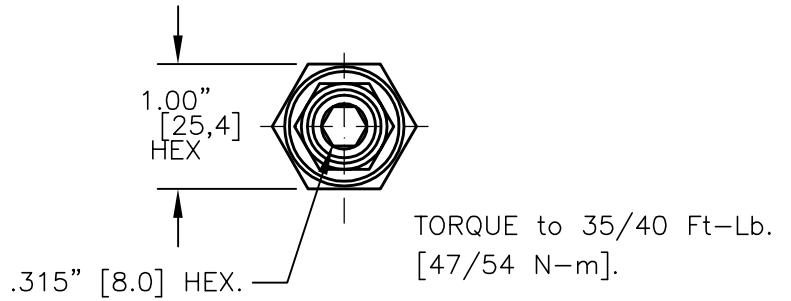

FOR ALUMINUM OR STEEL VALVE HOUSING CONFIGURATIONS SEE PAGE 0-011.1

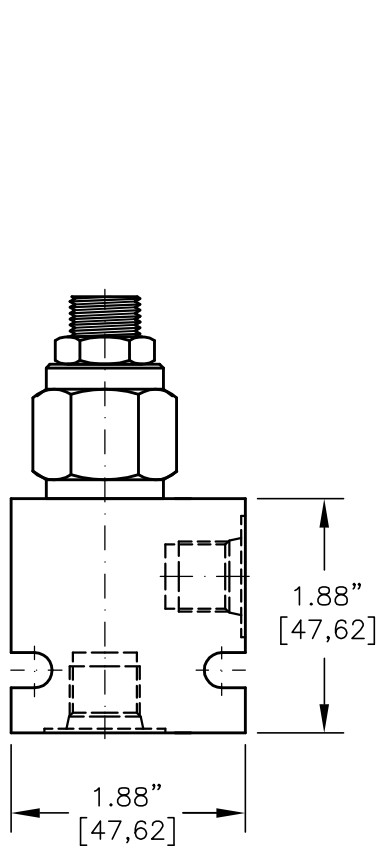
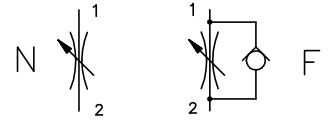
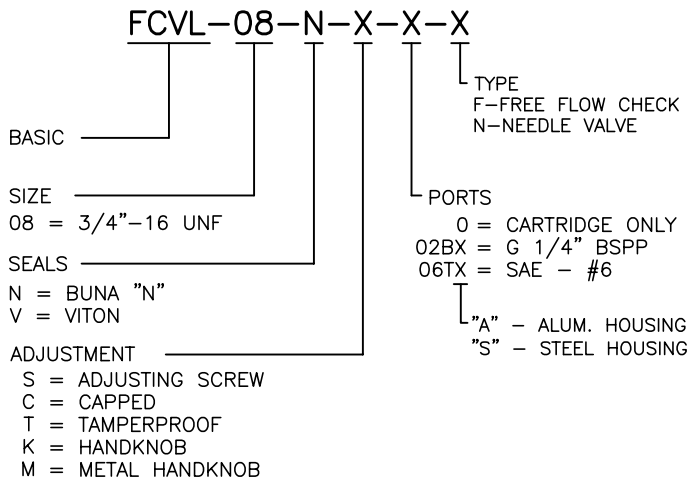

FOR ADJUSTMENT CONTROL OPTIONS SEE PAGE 0-050.0

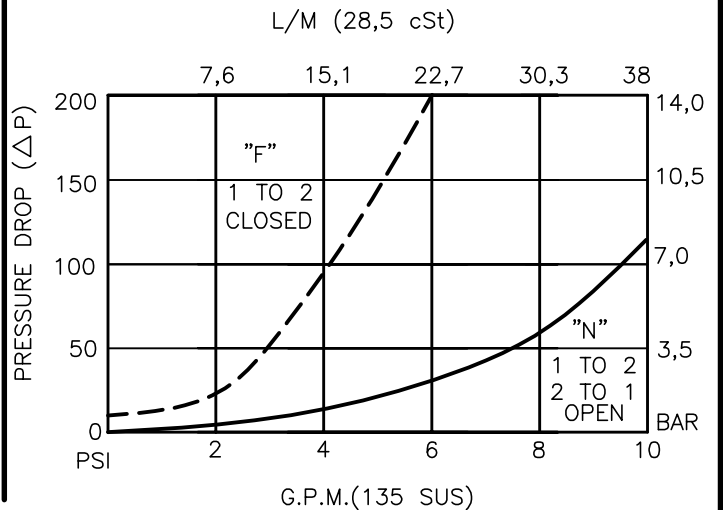



FLOW CONTROL VALVE WITH OR WITHOUT FREE REVERSE FLOW CHECK

DESCRIPTION

This unit is a SCREW IN, cartridge type, adjustable, poppet type, hydraulic flow control valve with or without free reverse flow check.

OPERATIONS

This valve increases its orifice value from fully closed to fully open with counter-clockwise rotation.

FEATURES AND BENEFITS

Desired settings can be locked down.
Valve adjustment is difficult while subjected to high pressure.
Valve is available with a screw, tamperproof, capped or knob adjustment.
All external carbon steel parts are plated for longer life against the elements.
All cartridge valves are 100% functionally tested.
Industry common cavity.

SPECIFICATIONS

OPERATING PRESSURE: 5,000 PSI [350 Bar]

PROOF PRESSURE: 10,000 PSI [700 Bar]

FLOW: 10.0 GPM [38,0 l/m] nominal. See performance chart.

INTERNAL LEAKAGE: 5 drops per minute maximum @ 5,000 PSI (350 Bar)

VALVE HOUSINGS: 2500 PSI [175 Bar] = Aluminum - Anodized.

5000 PSI [350 Bar] = Steel - Unplated.

OPERATING TEMPERATURE: -40° to +250° F. [-40° to +120° C.]

OPERATING MEDIA: All general purpose hydraulic fluids such as
MIL-H-5606, SAE-#10, SAE-#20, etc.

INSTALLATION: No restrictions.

SEAL KIT: SKN-0822 Buna "N".

SKV-0822 Viton.

WEIGHT: .30 lb [.14 kg] cartridge only.

VALVE CAVITY: #C0820, See Page 0-011.0.